



CHL-350

Great capacity

The new CHL-350 machine offers professional features, great projection capacity and a robust design.

- Great projection capacity of polyurethane and polyurea.
- Pump direction change system with limit switches.
- Pump cycle counter.
- Protected electrical wiring.
- Double product pump through reciprocal system.
- Digital automatic control of temperatures.
- Protective casings for added security.
- Overpressure protection system.
- Configurable temperature of the heaters.
- Adjustable pressure.
- ISO automatic lubrication system.
- Heated product hoses.
- Electric heaters.
- Own design and manufacturing.



SOLIDWORKS



Security protections



Adjustable pressures



Adjustable temperatures



Cycle counter



Made in Spain

Model	CHL-350
Production	12 L/min
Work pressure	2900psi (200 bar)
Electrical power supply	400 V, triphasic*
Maximum hose length	295 ft (90m)
Heaters	18.000w (total)
Weight (with/without hydraulic fluid)	727 lb / 573 lb (330 Kg / 260 Kg)
Dimensions (width x depth x height)	3.2 x 2.7 x 4.1 ft (970 x 840 x 1255 mm)
Electric motor power	5.500 w
Transformer power	6.000 w

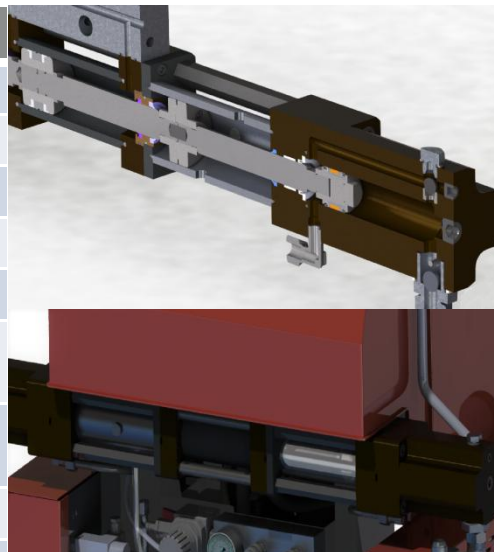

Characteristics

The electrical panel is built without delicate electrical circuitry.

CE certificate.

Monitoring of pressures and temperatures of the material at the outlet.

The changeover system with limit switches and controlled by relays allows to avoid piston strokes and to have a long useful life.

The programmable cycle counter allows the machine to stop automatically to change the drums before emptying them. This avoid possible cavitation, vacuums work and incomplete mixing.

All components are easily replaceable and are in stock.

The machine uses a reciprocating piston pump with ball valves which is the industry standard.

The temperature sensors work in real time, sending a signal to the controller to keep the chemicals at the desired temperature. Thermocouples that measure temperature can easily be replaced if they fail.

The design with easily removable safety guards prevents accidents and allows for easy maintenance.

ISO automatic lubrication system.

Standard: 400 V triphasic current; 18kW power heaters; 2900psi working pressure.

* Consult for other configurations.

Optional equipments

Spray gun
Transfer pumps
Compressors

Spray gun accesories
Heated hoses
Air dryers

Recirculation Kits
Heating drum bands
Electric generators