



# CHL-400

## Even more capacity

The new CHL-400 Touch Screen machine offers professional features, great projection capacity and a robust design.

- Great projection capacity of polyurethane and polyurea.
- Touch screen for machine management.
- Pump direction change system with limit switches.
- Pump cycle counter.
- Protected electrical wiring.
- Double product pump through reciprocal system.
- Digital automatic control of temperatures.
- Protective casings for added security.
- Overpressure protection system.
- Configurable temperature of the heaters.
- Adjustable pressure.
- ISO automatic lubrication system.
- Heated product hoses.
- Electric heaters.
- Own design and manufacturing.



Security protections



Adjustable pressures

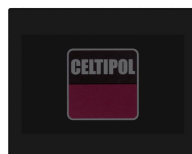

Adjustable temperatures

Cycle counter



Made in Spain

Model	CHL-400
Production	18 L/min
Work pressure	2900psi (200 bar)
Electrical power supply	400 V, triphasic*
Maximum hose length	295 ft (90m)
Heaters	21.600w (total)
Weight (with/without hydraulic fluid)	727 lb / 573 lb (330 Kg / 260 Kg)
Dimensions (width x depth x height)	3.2 x 2.7 x 4.1 ft (970 x 840 x 1255 mm)
Electric motor power	7.500 w
Transformer power	6.000 w

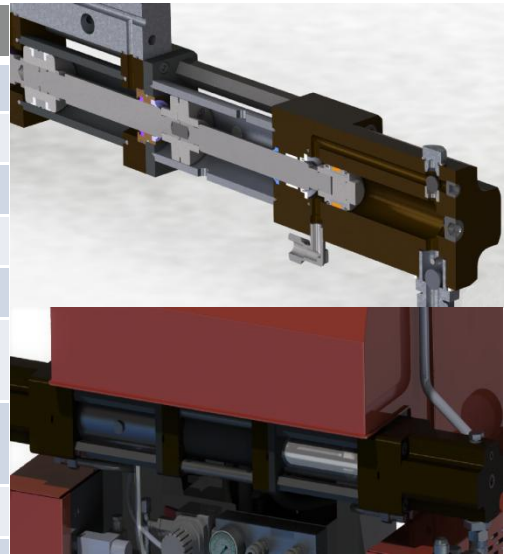

## Characteristics

Touch screen for machine management.

Selection of pressures, temperatures and operating cycles on the touch screen.

The electrical panel is built without delicate electrical circuitry.

CE certificate.

Monitoring of pressures and temperatures of the material at the outlet.

The changeover system with limit switches and controlled by relays allows to avoid piston strokes and to have a long useful life.

Programmable cycle counter.

All components are easily replaceable and are in stock.

The machine uses a reciprocating piston pump with ball valves which is the industry standard.

The temperature sensors work in real time, sending a signal to the controller to keep the chemicals at the desired temperature. Thermocouples that measure temperature can easily be replaced if they fail.

The design with easily removable safety guards prevents accidents and allows for easy maintenance.

ISO automatic lubrication system.

Standard: 400 V triphasic current; 21.6kW power heaters; 2900psi working pressure. \* Consult for other configurations.

## Optional equipments

Spray gun  
Transfer pumps  
Compressors

Spray gun accessories  
Heated hoses  
Air dryers

Recirculation Kits  
Heating drum bands  
Electric generators